

# MDR SPIRAL CURVE

## Series 1500 ETO Conveyor Module

Controls Platform: G20 Full Control

POWERED BY  
**TREW**®

Spiral curve modules can be used as a stand-alone elevation change or combine together to create an inclining or declining spiral, which allows for an elevation change in a small footprint. The pre-wired spiral curve module has built-in zero pressure accumulation and can be networked with bus technology, which enables custom control and fully visible diagnostics. All electric operation ensures a consistent and quiet system that is easy to maintain.

- Minimum Product Size 8" X 8"
- Up to 180 FPM
- Gear Ratio 21:1
- Up to 75 lbs
- O-Band

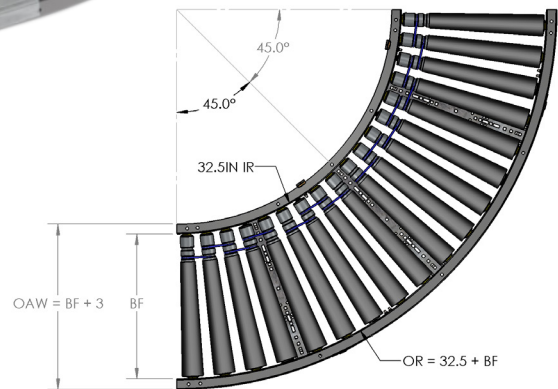
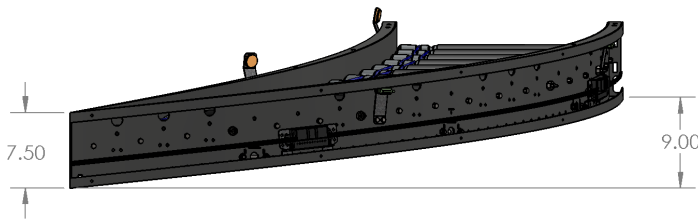
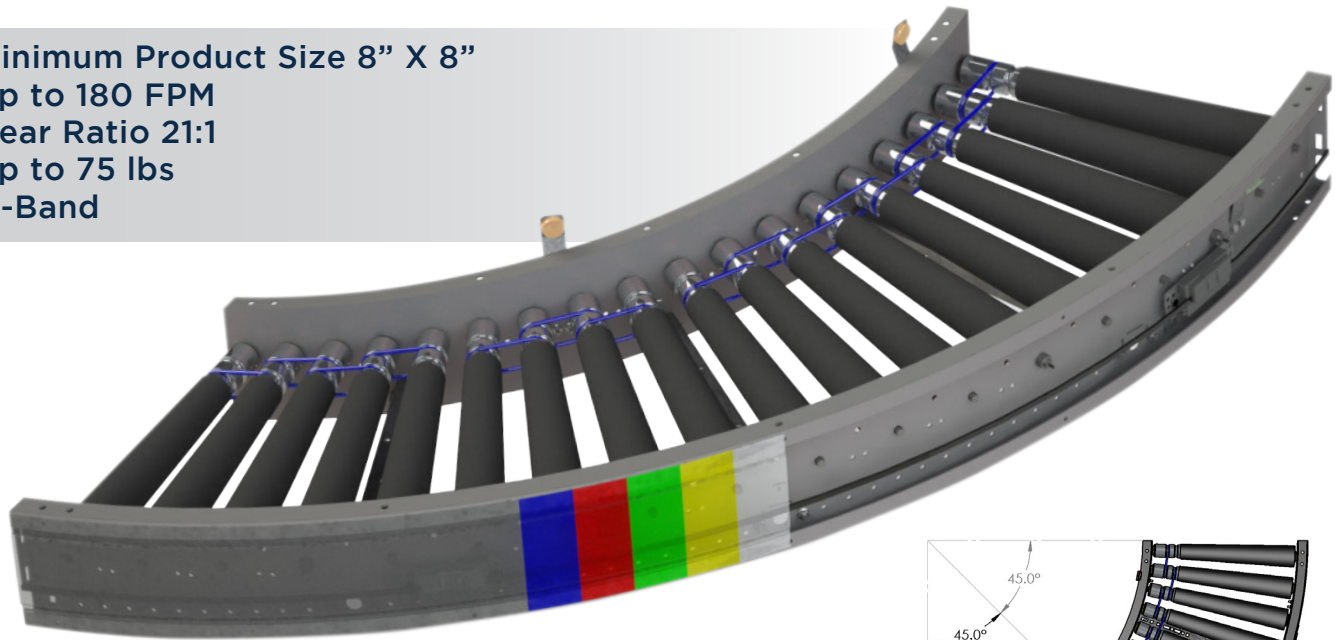

## KEY FEATURES AND BENEFITS

- Use as a stand-alone elevation change or combine together to create an inclining or declining spiral
- Light to medium weight applications up to 75 lbs
- Resilient and durable construction. Perfect for distribution, warehouse, process lines and postal applications
- Tool-less mounting brackets for all electrical components
- Electrical components have quick connect terminals for easy installations and expansion
- Using durable, high tension 5/16 O-bands
- Available ZPA Analyzer allows for system diagnostic and commissioning
- IP54 Standard