

# DOUBLE / TRIPLE PICK & PASS

## Series 1500 Conveyor Module

Controls Platform: G20 Full Control

POWERED BY

# TREW<sup>®</sup>

We help automate traditional pick and pass transfer applications with our new HCAT90 transfer unit design. The MDR double and triple pick and pass transfer modules can reach 40 cartons per minute (CPM). This system can route cartons or totes to zones that require picking, getting product to every operator without stopping. It is fast and efficient, perfect for pick-to-light or voice-pick systems.

- 9" Minimum Product Size
- Up to 180 FPM
- Available in 18:1 (geared)
- Up to 75 lbs
- Timing Belt

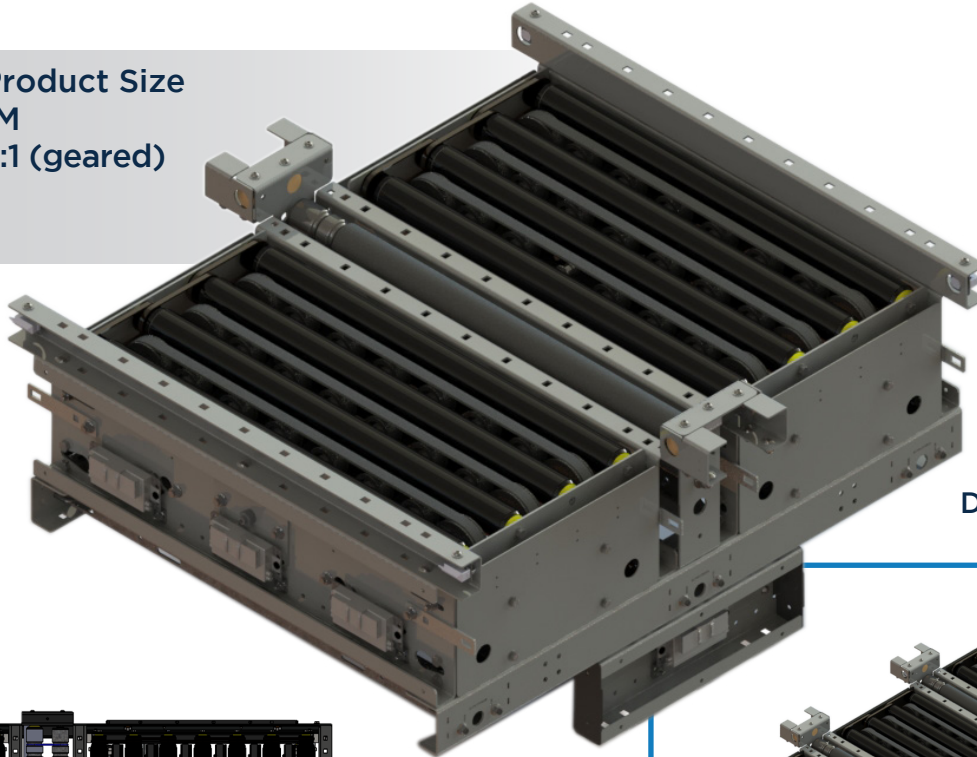

Double Pick & Pass

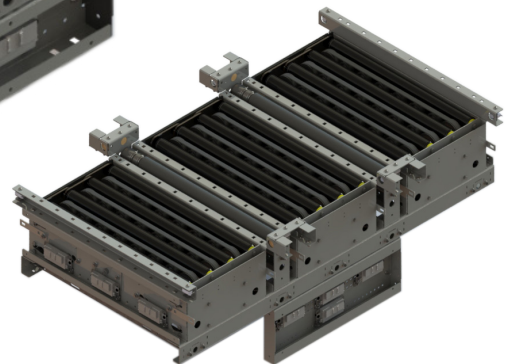
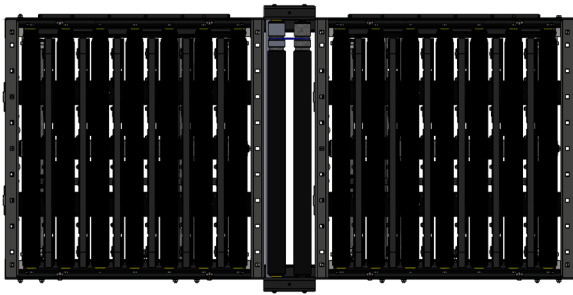

Triple Pick & Pass

## KEY FEATURES AND BENEFITS

- Rate up to 40 products per min (Conditional on Application)
- Light to medium weight applications up to 75 lbs
- Resilient and durable construction. Perfect for distribution, warehouse, process lines and postal applications
- Tool-less mounting brackets for all electrical components
- Available ZPA Analyzer allows for system diagnostic and commissioning
- Electrical components have quick connect terminals for easy installations and expansion
- Programming Required

# DOUBLE / TRIPLE PICK & PASS

## Series 1500 Conveyor Module



### SERIES 1500 CONVEYOR - DOUBLE PICK & PASS

Part #	Width (BF)	Gap	Side Channel	Roller C-C"	MDR Type	Hand	Control	Color
TR15144 (24" Zone) TR15146 (30" Zone) TR15148 (36" Zone)	15, 21, 27, 33, 36	3"	RSL	4"	EC5000 (geared)	LH RH	AUTO FULL	F9022 F7035
TR15143 (24" Zone) TR15145 (30" Zone) TR15147 (36" Zone)	15, 21, 27, 33, 36	6"	RSL	4"	EC5000 (geared)	LH RH	AUTO FULL	F9022 F7035

### SERIES 1500 CONVEYOR - TRIPLE PICK & PASS

Part #	Width (BF)	Gap	Side Channel	Roller C-C"	MDR Type	Hand	Control	Color
TR15150 (24" Zone) TR15152 (30" Zone) TR15154 (36" Zone)	15, 21, 27, 33, 36	3"	RSL	4"	EC5000 (geared)	LH RH	AUTO FULL	F9022 F7035
TR15149 (24" Zone) TR15151 (30" Zone) TR15153 (36" Zone)	15, 21, 27, 33, 36	6"	RSL	4"	EC5000 (geared)	LH RH	AUTO FULL	F9022 F7035

*Engineer to order options include: Additional BFs, additional zone lengths, additional MDRs & gear ratios, custom rail color. Additional options may be available upon request. Contact Trew Engineering for further information.*