

MDR BELTED INCLINE

Series 1500 Conveyor Module

Controls Platform: G20 Full Control

POWERED BY

TREW®

MDR belted incline modules have a high friction belt that holds product in location and helps maintain product alignment, perfect for print and apply applications and small and light products and bags. Pre-wired conveyor sections are networked with bus technology and are easily configured for multiple applications. All electric operation ensures a consistent and quiet system that is easy to maintain.

- 4" x 4" Minimum Product Size
- Up to 150 FPM
- Available in 21:1 (geared)
- Up to 50 lbs

Up to a 15 Degree Incline

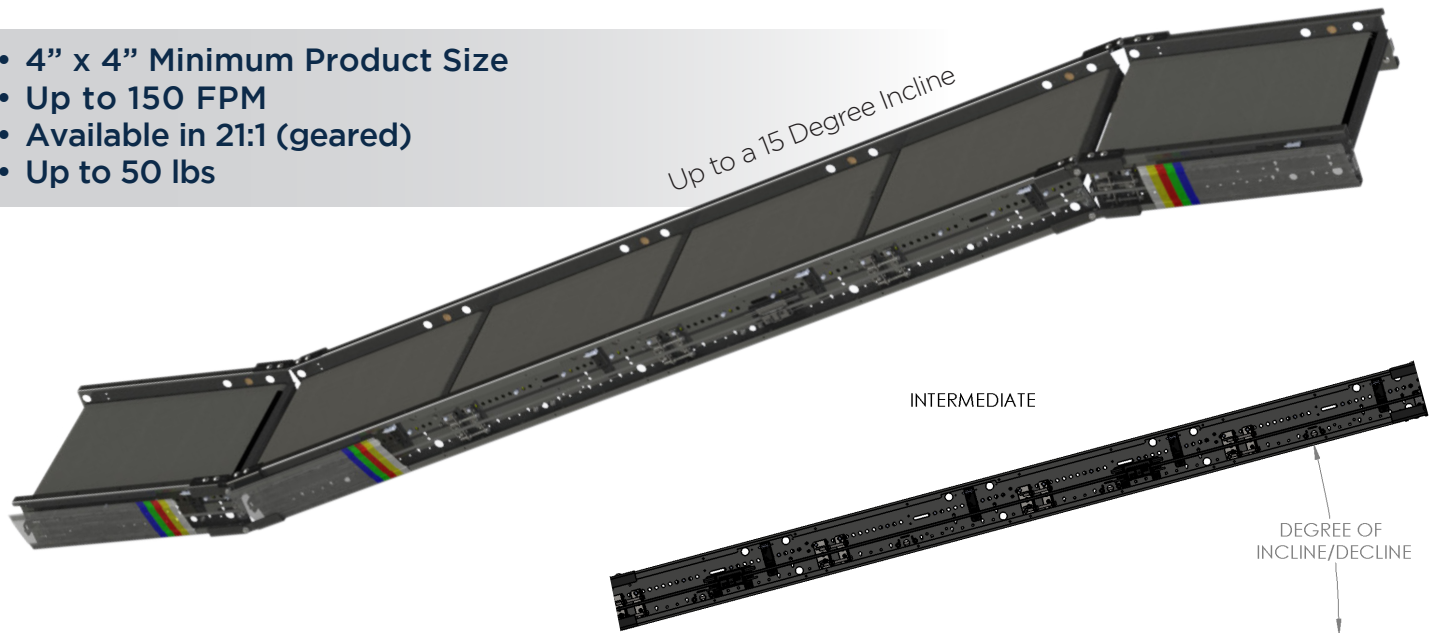

KEY FEATURES AND BENEFITS

- Sensitive Product Handling
- Take Up Bracket Per Zone for Belt Alignment
- T-Strip between belts for smaller products transition
- Ultra Co-Efficient Pyramid Belt Surface for higher traction & durability
- Light to medium weight applications up to 50 lbs
- Resilient and durable construction. Perfect for distribution, warehouse, process lines and postal applications
- Tool-less mounting brackets for all electrical components
- Electrical components have quick connect terminals for easy installations and expansion
- Using durable, high tension belt
- Available ZPA Analyzer allows for system diagnostic and commissioning
- IP54 Standard

MDR BELTED INCLINE

Series 1500 Conveyor Module



SERIES 1500 CONVEYOR - MDR BELTED INCLINE, RSL, 24" ZONE

Part #	Width (BF)	Side Channel	MDR Type	Hand	Control	Color
TR15092 (24" Long)	15, 21, 27, 33, 36	RSL	EC5000 (geared)	LH	AUTO	F9022
TR15093 (48" Long)				RH	FULL	F7035
TR15094 (96" Long)						
TR15095 (144" Long)						

SERIES 1500 CONVEYOR - MDR BELTED INCLINE, RSL, 30" ZONE

Part #	Width (BF)	Side Channel	MDR Type	Hand	Control	Color
TR15096 (30" Long)	15, 21, 27, 33, 36	RSL	EC5000 (geared)	LH	AUTO	F9022
TR15097 (60" Long)				RH	FULL	F7035
TR15098 (120" Long)						

SERIES 1500 CONVEYOR - MDR BELTED INCLINE, RSL, 36" ZONE

Part #	Width (BF)	Side Channel	MDR Type	Hand	Control	Color
TR15099 (36" Long)	15, 21, 27, 33, 36	RSL	EC5000 (geared)	LH	AUTO	F9022
TR15100 (72" Long)				RH	FULL	F7035
TR15101 (144" Long)						

Engineer to order options include: Additional BFs, additional zone lengths, additional MDRs & gear ratios, alternative photoeye locations, RSH (5.5" frame depth), food grade belts/textures, split zones, custom rail colors. Additional options may be available upon request. Contact Trew Engineering for further information.